



JOYCE/DAYTON CORP.

P.O. Box 1630

Dayton, OH 45401

(800) 523-5204 (U.S. & Canada)

Sales@JoyceDayton.com

<http://www.joycedayton.com>

MACHINE SCREW JACKS

METRIC MACHINE SCREW JACKS

STAINLESS STEEL MACHINE SCREW JACKS

MACHINE SCREW COMDRIVE[®] ACTUATOR

ORIGINAL INSTRUCTION MANUAL – FB0173

sales@joycedayton.com

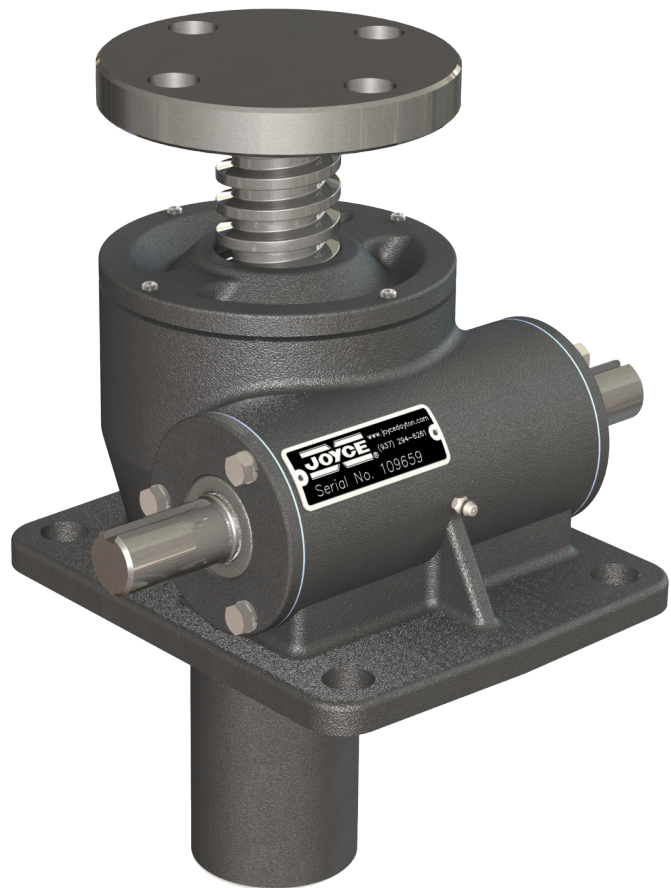

Product Safety Information

IMPORTANT

Information within this manual **MUST** be followed to ensure safe use. All persons responsible for design, installation, operation, and maintenance of Joyce Machine Screw Jacks must be familiar with the contents of this manual. This manual forms part of the screw jack and should be kept with the equipment at all times. Keep the manual updated to the latest revision by the manufacturer .

A machine screw jack is a power transmission device and as such proper precautions must be followed to ensure safety. Some of those precautions are outlined within the following paragraphs. The information provided is the best assessment of hazards based on current state of knowledge. Further guidance for use should be obtained by contacting Joyce Dayton application engineering directly.

1) Design and Selection

- (a) Machine screw jacks are designed for industrial use only.
- (b) Jacks are not to be used to lift or support people. Contact Joyce Dayton Corp. directly if that use is required.
- (c) Hard screw stops and travel limits are the responsibility of the customer and **MUST** be installed to prevent over travel or possible falling load. It is the customer's responsibility to provide travel limit devices on all jacks. A mechanical stop is only an auxiliary device to limit the travel of the lifting screw. Engaging a mechanical stop during operation can cause damage to the internal jack mechanism.
- (d) Model selection must be done correctly to ensure satisfactory performance, avoidance of detrimental critical speeds, and prevention of premature failure. Jacks are not rated for shock loading, extreme vibration, or critical speed conditions. It is the responsibility of the user to ensure these conditions are not imposed on the actuator or the power transmission equipment.
- (e) Jack parameters, (e.g., static load, dynamic load, maximum screw travel, input speed, duty cycle) must be verified acceptable before operation. Jacks are to be operated only in the environments and temperatures for which they are designed.
- (f) The contents of this manual are not binding nor are they all inclusive. Joyce Dayton Corp. may make changes to the content as required to ensure safety and improve upon jack designs.

2) Installation, Maintenance, and Storage

- (a) Installation must be performed only by qualified personnel. Do not perform unauthorized modifications to the jack equipment.
- (b) Equipment may be shipped with corrosion inhibitors or similar materials applied. In addition, shipping crates and fasteners may pose laceration hazards. Proper safety equipment must be used.
- (c) Equipment constitutes heavy machinery and poses falling loads hazards. Proper lifting and handling processes must be followed. Loads **MUST** be secured or removed prior to servicing.
- (d) Jack components are to be replaced only with Joyce Dayton approved substitute parts. Consult the applicable sections within this manual before dismantling or performing any maintenance work.

3) Operation

- (a) Jacks are only to be used when in technically good condition. Never operate a jack that is damaged, improperly maintained, or not securely fastened. Jacks are to be inspected by qualified personnel prior to every use and any part defects are to be repaired or replaced immediately.
- (b) Jacks are only to be operated between the temperatures of 40°F and 220°F. For operation beyond these temperature limits Joyce Dayton engineering is to be contacted.
- (c) Jacks are not designed for side loading. Jacks are not designed to withstand shock-loading, extreme vibration, or critical speed conditions (high speed or long length screw).
- (d) It is the responsibility of the user to fit jacks with travel limits and additional safety devices, (e.g., external hard stops, etc) as required to prevent falling load in the event of equipment failure.
- (e) Jacks must be mounted on rigid structures sufficient to support maximum operating loads. Premature wear or failure can result from use on under designed structures.

Contents

1	USE OF THIS INSTRUCTION MANUAL	5
2	SAFETY	
	2-1 Use for the Intended Purpose	5
	2-2 Responsibilities of the User	5
	2-3 Hazard Identification	6
	2-4 Personal Protection Equipment (PPE)	6
3	WARRANTY	6
4	PRODUCT DESCRIPTION	
	4-1 Overview	7
	4-2 Common Screw Jack Configurations	8
	4-3 Serial Tag	9
	4-4 Technical Data	9
	4-5 Screw Jack Options requiring customer input/maintenance	9
5	TRANSPORT AND STORAGE	
	5-1 Transport	10
	5-2 Storage	10
6	INSTALLATION AND COMMISSIONING	
	6-1 General	10
	6-2 Lifting	10
	6-3 Mounting to Structures	11
	6-4 Attaching Shafts and Couplings	11
	6-5 Attaching Motors	11

6-6	<i>Making Electrical Connections</i>	11
6-7	<i>Commissioning</i>	12
7	OPERATION AND MAINTENANCE	
7-1	<i>Inspection</i>	12
7-2	<i>Lubrication</i>	12
7-3	<i>Operation</i>	13
7-4	<i>Lifting Nut Inspection</i>	14
7-5	<i>Troubleshooting</i>	15
8	EMERGENCY OPERATIONS	16
9	DECOMMISSIONING & RECOMMISSIONING	16
10	DISPOSAL	16
11	REPAIR & REPLACEMENT	
11-1	<i>Repair Parts</i>	16
11-2	<i>Disassembly</i>	17
11-3	<i>Inspection</i>	19
11-4	<i>Reassembly</i>	19
 <i>LIST OF TABLES/FIGURES</i>		
•	<i>Component Schematic and parts list</i>	21
•	<i>Jack Weights</i>	26
•	<i>Maintenance Record</i>	27

SECTION 1

USE OF THIS INSTRUCTION MANUAL

This manual contains technical information for operation and safety of Joyce/Dayton (J/D) machine screw jacks.



NOTE: Due to constant improvements in jack design and safety, this manual is subject to ongoing revision. The contents are therefore not binding and are subject to change without notice.

- The manual together with similar documents constitutes part of the equipment and shall be kept the entire life of the equipment.
- The manual shall accompany the product in the event of owner exchange.
- Additional information required for operation can be obtained on the web at www.joycedayton.com and within the product catalog.

SECTION 2

SAFETY

2-1 USE FOR THE INTENDED PURPOSE

The Joyce/Dayton machine screw jack is suitable only for translating, positioning, and sustaining loads within the specified capacity. Responsibility to ensure correct use lies with the user/integrator. All operational parameters MUST be verified acceptable before use.

2-2 RESPONSIBILITIES OF THE USER





Joyce/Dayton machine screw jacks are designed and manufactured with due regard for safety. However, hazards to life and limb of the users or third parties, or risks of damage to the Joyce/Dayton Screw Jack and other property, may arise during use.

To mitigate risks, users are required to read and understand all product safety information within this manual. This manual is not all inclusive; however, basic safety precautions which must be followed have been listed.

The end user/integrator must perform thorough risk analyses for integration into the final machine system. Safety provisions are the responsibility of the user/integrator.

2-3 HAZARD IDENTIFICATION

Hazard text is included throughout this manual to emphasize potentially harmful conditions. The meanings of the text are defined below.

Symbol	Meaning
 DANGER!	Indicates death or serious injury will result if proper precautions are not taken.
 WARNING!	Indicates death, serious injury, or property damage can result if proper precautions are not taken.
 CAUTION!	Indicates some injury or property damage may result if proper precautions are not taken.
 NOTE!	Information demanding special attention.

2-4 PERSONAL PROTECTION EQUIPMENT (PPE)

	WARNING: SERIOUS INJURY OR DEATH! Proper personal protection equipment must be worn during use.
--	--

Personal protection equipment must be worn to minimize exposure to hazards that may cause workplace injury or illness. Review relative OSHA standards for approved safety equipment. It is not possible for Joyce Dayton to assess all necessary safeguards for jack implementation due to the multitude of varying end uses. However, basic use of the jack requires that proper protective clothing, (e.g., no loose ends or hanging objects), gloves, eye wear, and footwear be worn during use.

SECTION 3

WARRANTY

Seller warrants its products to be free from defects in material and workmanship under normal and proper use in accordance with instruction of seller for a period of one year from the date of shipment to buyer. Seller's liability under such warranty or in connection with any other claim relating to the products shall be limited to the repair, or at seller's option, the replacement or refund of the purchase price, of any products or parts or components thereof which are returned to seller, freight prepaid, and which are defective in material or workmanship. Products or parts of components, thereof, which are repaired or replaced by seller, will be returned to buyer freight collect. This warranty is not intended to cover consumer products, as defined in the Magnuson-Moss Warranty-Federal Trade Commission Improvement Act, 15 U.S.C. Sections 2301-12, which are purchased by buyer for purposes other than resale. If the buyer is not intending to resell the products and if the products are consumer products as defined in the Magnuson-Moss Act, the foregoing warranty, but not the limitation of seller's liability, shall be null and void. EXCEPT AS EXPRESSLY STATED ABOVE, SELLER MAKES NO WARRANTY, EXPRESS OR IMPLIED, WHETHER OF MERCHANTABILITY OR FITNESS FOR ANY PARTICULAR PURPOSE OR USE OR OTHERWISE, ON THE PRODUCTS, OR ON ANY PARTS OR LABOR FURNISHED DURING THE SALE, DELIVERY, OR SERVICING OF THE PRODUCTS.

SECTION 4

PRODUCT DESCRIPTION

4-1 OVERVIEW

Joyce/Dayton machine screw jacks convert rotary motion into linear motion through the conventional use of a worm gear set. The fundamental purpose is to translate loads. A basic jack assembly is depicted below.

Per Machinery Directive 2006/42/EG, screw jacks are considered partly completed machinery. Screw jacks are designed and manufactured to be integral subcomponents of final machinery. A proper risk analysis must be performed by the final system integrator to ensure safe operation.

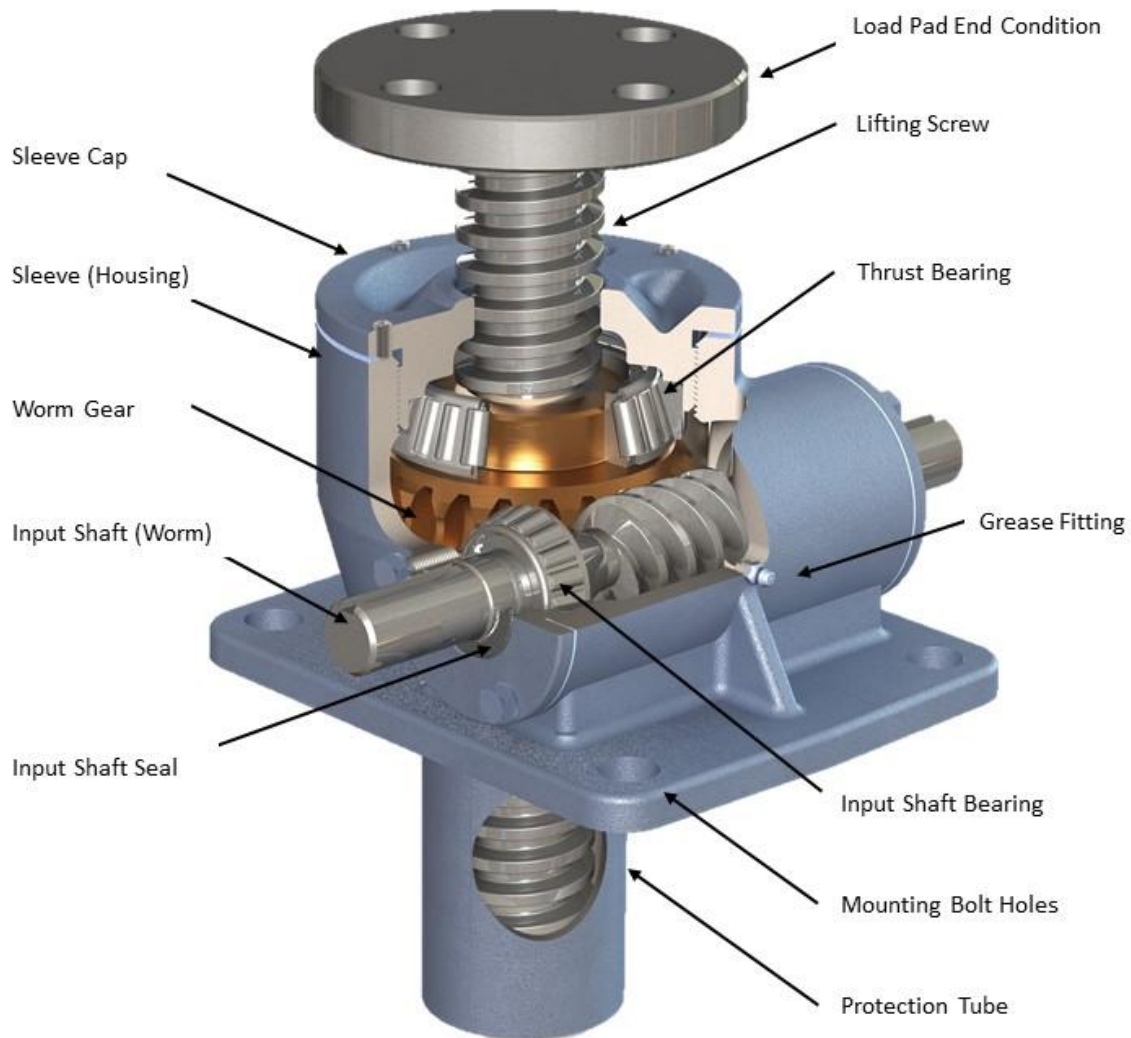

4-2 COMMON SCREW JACK CONFIGURATIONS

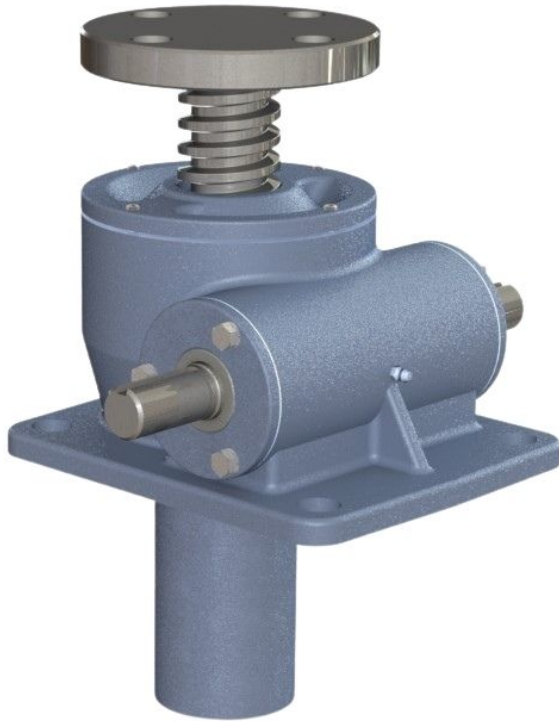

Translating Screw Jack

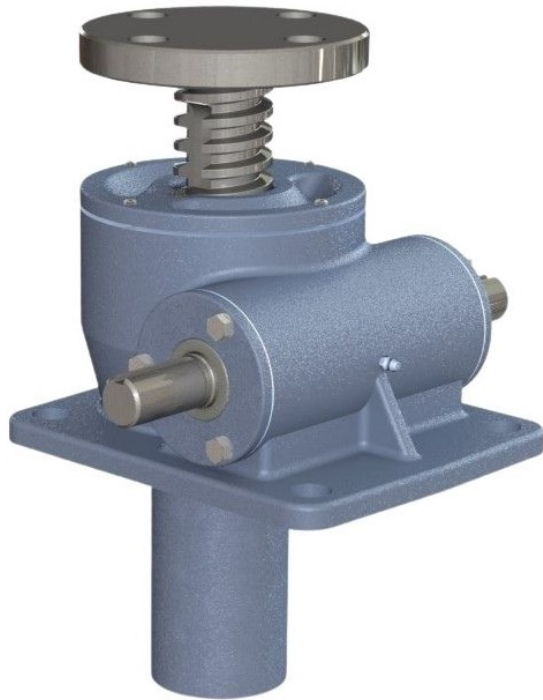

Keyed Jack

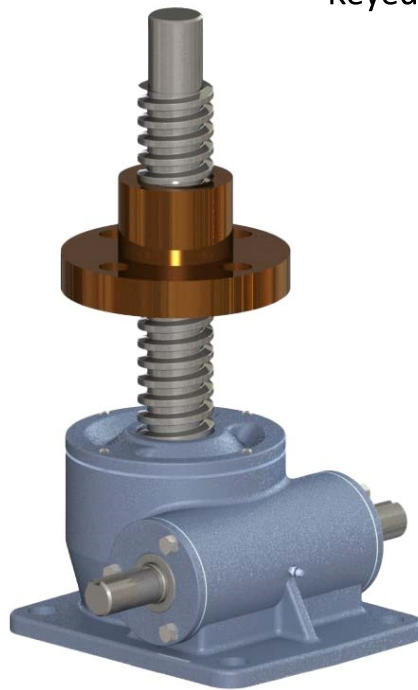

Traveling Nut Jack

4-3 SERIAL TAG

All J/D screw jacks ship with a unique identifying serial number attached. The serial number is recorded on a metal tag secured to the jack sleeve. When contacting Joyce/Dayton reference the serial number to ensure proper unit identification.

4-4 TECHNICAL DATA

ALL screw jack operational parameters including static and dynamic maximum capacities must be verified before use to ensure proper operation and prevention of premature failure. Static and dynamic capacities depend highly on other operational parameters, (e.g., column length and input speed) and may be considerably less than the standard listed capacity.

Designers/users are to reference Joyce/Dayton JAX software, available at JoyceDayton.com/jax-online, for detailed technical information. Basic operational parameters, including torque input requirements and maximum column load, are available within the Joyce Dayton product catalog. Contact Joyce/Dayton directly for more assistance.

4-5 SCREW JACK OPTIONS REQUIRING CUSTOMER INPUT/MAINTENANCE

Machine screw jacks often include options and accessories. Some of the available options are listed below.

1. ANTI-BACKLASH DEVICES:

Anti-backlash devices are used to limit the backlash (free movement between the lifting screw and nut) in machine screw jacks. They are typically used in reversing load applications. Joyce/Dayton offers three unique designs; each uses the same concept of clamping two independent nut halves against the lifting screw threads.

- *Split Gear Design (A)* – This device is best suited for light dynamic loads (1/3 jack capacity or less) and full jack capacity for static loads. A split gear and dowel pins maintain gear alignment. They are adjusted by tightening the sleeve cap. These typically reduce endplay to 0.010”-0.015” and are available on translating and KFTN models, 500-pound to 75-ton and on some keyed models.
- *A90 Design (A90)* – This device is best suited for medium dynamic loads (1/2 to 3/4 jack capacity) and full jack capacity for static loads. It incorporates a hardened steel plate pinned to the top of the internal gear and a secondary nut placed above the steel plate. Setting the backlash is accomplished by tightening the dog point set screws located inside the secondary nut. The set screws are externally adjustable. These typically reduce endplay to 0.008” – 0.012”. They are available on upright translating designs 25 tons to 100 tons.
- *A95 Design (A95)* – This device is capable of handling full jack capacity in dynamic and static conditions. It allows the gear teeth to remain intact and therefore retain their full load carrying capacity. Adjust endplay by tightening the sleeve cap. These typically reduce endplay by 0.008” – 0.012”. They are available on upright and inverted translating models, 1-ton to 150-ton.

2. DISPLACEMENT DEVICES:

- *Cam Limit Switches* - Limit switches are optional. If purchased these are not shipped preset and therefore MUST be set during installation.
- *Potentiometers & Encoders* - Geared potentiometers and encoders must be tied into your control system. Follow manufacturer’s instructions to set them.

SECTION 5

TRANSPORT AND STORAGE

5-1 TRANSPORT

	CAUTION: INJURY OR DAMAGE! Personal protective equipment should be worn.
---	--

For protection, anti corrosion lubricant may be applied to the bare steel surfaces of jacks (e.g., lead screw and input shaft) prior to shipment. A minor skin irritation risk may be present with such materials. In addition, the jacks are typically secured within wooden crates for shipment. Possible laceration risks and heavy/falling load risks are present with the packaging. Standard safe practices should be observed during shipping and opening.



5-2 STORAGE

If extended storage (>6 months) is required contact J/D directly for additional storage provisions.

SECTION 6

INSTALLATION

6-1 GENERAL

	WARNING: FALLING LOAD HAZARD! Jack equipment is heavy machinery and may constitute a heavy/falling load risk. Use proper handling methods during installation.
	CAUTION: INJURY OR DAMAGE! Wear proper personal safety equipment during unpacking and installation.

- Prior to installation perform 100% visual inspection of the jack to ensure no damage occurred during shipping or storage. Contact the freight forwarder if damage is found.
- Verify the serial number of the jack unit against packing slip.
- Be certain that the rated capacity of the screw jack exceeds the maximum load that may be applied to it during use
- Check that the maximum allowable input speed (RPM) of the screw jack will not be exceeded
- Note: For maximum input speeds and other Joyce Dayton specifications refer to Jax software located at www.JoyceDayton.com
- Select a motor (if used) of appropriate size for your application. For motor sizing information, refer to Jax software located at www.JoyceDayton.com

6-2 LIFTING

- When hoisting or raising the lifting straps shall be attached as close as possible to the jack housing.
- Approximate jack weights are listed in the table on page 22 of this manual.
- The input shafts and lead screw can turn, use caution when strapping to these surfaces.

- Jack assemblies can be large and therefore constitute heavy/falling load risks. Proper handling operations must be followed to mitigate risks.

6-3 MOUNTING TO STRUCTURE

- Jacks must be mounted to a rigid structure sufficient to support maximum load. An under-designed structure will create compliance and possible bending stresses that will result in premature failure of the jack.
- Jacks must be mounted using S.A.E. Grade 8 or equivalent bolts.
- Mounting bolts are to be fastened in a staggered pattern to ensure even clamping forces and prevent damage to the sleeve.
- Mount the screw jack and check that the axis of the load screw is parallel to the movement of the load and centered with respect to the load. If required, shim under the screw jack base so that this condition is achieved. After re-checking that alignment is correct, hand tighten the mounting bolts. Repeat this step for each screw jack to be installed in the system.



Caution: Eccentric loading and/or side loading will result in premature wear and/or damage the screw jack and possibly other components in the system. Such damage is not covered under the Joyce Dayton warranty

- **Important:** To help ensure proper alignment, the use of laser transits during alignment procedures is strongly recommended

6-4 ATTACHING SHAFTS AND COUPLINGS

- Input shafts have typical tolerances of $+0.000/-0.002$ inches on the nominal size. Female mating components are to have a comparable tolerance to ensure proper engagement.
- Drive shaft alignment is CRITICAL. Misalignment will cause reversing stresses in the rotating members and will lead to fatigue failure. Correct coupling specification is important.
- Ensure all surfaces are free of burrs and nicks prior to attachment. A light coating of oil/grease may aid assembly.
- Do not hammer components onto the input shaft. Impact forces may damage the internal bearings.
- Shaft and coupling guards are required and are the responsibility of the user.

6-5 ATTACHING MOTORS

- Motors shall be sized appropriately for the load and duty cycle of the screw jack.
- Motors shall be fastened securely onto the jack input shaft. Motors shall be fastened rigidly to the jack or onto a shared jack mounting platform to ensure alignment.

6-6 MAKING ELECTRICAL CONNECTIONS



WARNING: ELECTRICAL SHOCK RISK! Only qualified persons shall perform electrical work.

- All electrical work is to be conducted by qualified personnel. Proper cable and terminal sizing MUST be conducted to ensure safe and proper operation.
- Ensure all electrical cables/lines are free from the moving input shaft/lead screw to prevent possible severing.

6-7 COMMISSIONING

- Ensure all safety provisions are in place and functioning prior to operation.
- Commissioning should only be performed by qualified personnel.
- Initial run tests should be conducted WITHOUT load to verify proper operation.
- Load should be increased slowly during initial operating periods.
- Operating parameters MUST be maintained within limits at all times.
- Optional limit switches, if attached, are NOT preset and require adjustment before use.
- In a system with shafts, miter boxes, etc., confirm that the shafts and jacks operate without binding or excessive force before powered drive devices are engaged.
- Boots or protective bellows should be used to protect and keep the lifting screw clean in dusty or abrasive environments.



SECTION 7

OPERATION AND MAINTENANCE

7-1 INSPECTION

- Prior to every operation the jack is to be visually inspected to ensure no defects or damage is present.

7-2 LUBRICATION

	WARNING: Failure to maintain proper lubrication levels will result in significant damage to the equipment and possible premature failure. Re-lubrication and renewal of the grease is critical to successful operation and longevity.
	NOTE: Standard greases supplied in machine screw jacks are acceptable for operation between 40°F and 220°F, (4°C and 121°F). Contact Joyce Dayton engineering directly for proper lubricants to be used outside of this range.

- Jacks are lubricated before leaving the factory unless otherwise specified. During re-lubrication only grease of the same manufacturer and type as shipped should be added. Mixing of greases can be of serious detriment to jack operation and life and should be avoided! Please consult the Factory if unsure of what grease to use.
- Re-lubrication intervals are governed by usage and environment. Extended duty cycles at higher loads and speeds will consume more grease than at lower loads and occasional use. Periodically the jack should be checked to ensure an adequate film of grease exists on the jack lead screw.
- In addition, jacks should be regularly lubricated using the existing grease fittings every 40 hours of duty. The frequency should be increased for more demanding usage. Visual inspection of grease will determine proper lubrication frequency.
- The estimated volume of grease needed when re-lubricating jacks is ~10% - 15% of the full volume of the jack. Refer to Table 1 on the following page.
- After extended usage it is recommended that the grease be entirely purged from the jack and replaced. The grease shall be removed and replaced after 700 hours of operation or after 24 months at the latest.
- Re-lubrication must be performed correctly to ensure proper grease migration within the jack.
 - a) All jack grease fittings must have an equal amount of grease applied. The location of fittings may vary depending on the specific jack housing. Contact sales@joycedayton.com for assistance.
 - b) The grease amounts given in Table 1 are estimates. The jack may require more or less than the volume listed. Excess grease may escape around input shaft seals or around the jack lead screw during application. Visual grease ejection assures proper grease level within the jack. Excess grease should be wiped up and disposed of appropriately.

Table 1. LUBRICANT CHART - Estimated Volume of Grease for Replacement and Re-lubrication

Static Capacity (lbf)	Total Volume (fl oz.)	15% of Volume (fl oz.)	Static Capacity (lbf)	Total Volume (fl oz.)	15% of Volume (fl oz.)	Static Capacity (lbf)	Total Volume (fl oz.)	15% of Volume (fl oz.)
250-lb	1.0 oz.	.2 oz.	5-Ton	9.8 oz.	1.5 oz.	35-Ton	54.1 oz.	8.1 oz.
500-lb	1.0 oz.	.2 oz.	10_Ton	19.2 oz.	2.9 oz.	50-Ton	89.0 oz.	13.4 oz.
1000-lb	1.0 oz.	.2 oz.	15-Ton	24.5 oz.	3.7 oz.	75-Ton	392.4 oz.	58.9 oz.
1-Ton	1.7 oz.	.3 oz.	20-Ton	32.5 oz.	4.9 oz.	100-Ton	264.9oz.	39.7 oz.
2-Ton	3.4 oz.	.5 oz.	25-Ton	55.7 oz.	8.4 oz.	150-Ton	113.2oz.	17.0 oz.
3-Ton	5.3 oz.	.8 oz.	30-Ton	50.0 oz.	7.5 oz.	250-Ton	Contact Joyce/Dayton	

Lubricant

Standard Jack Grease - Mobilgrease XHP461, 40°F-220°F, Non-Food Grade

Standard ComDrive Reducer Lubricant - Mobilgear 630W oil

All other applications (High temperature, Low temperature, High speed, etc.) please contact Joyce Dayton

- Grease used to lubricate screw jacks is made up of base oils, thickeners, and additives. It is normal for oils to “bleed” or separate from the thickeners when stressed or stored for long periods of time. Some of the oils may escape the cavity during this process.
- Machine screw jacks are not designed to be completely sealed. The physics of operation allow lifting screws to translate through the body of the jack opening a path along which grease may escape from the internal cavity. The use of a boot, not only shields the screw, but also aids in collecting escaped grease.

ComDrive Reducer

- The oil in the reducer must be maintained at the proper level. The reducer must be at rest when the oil level is checked.
- In a new unit, the oil should be changed (or filtered) after four weeks (or 100 hours) of use. The case should be flushed with light oil to remove any foreign substances.
- After the initial oil change, the oil should be changed once every 6 months or 2500 hours, whichever occurs first.
- More frequent oil changes may be necessary when there are severe duty or dirty conditions present.
- Special order speed reducers supplied with ComDRIVE® actuators may or may not be factory lubricated. In this case, a separate O&M can be provided for the special reducer.

7-3 OPERATION

	<p>WARNING: Failure to operate jack within equipment limits will cause damage and premature failure. Ensure operation within both STATIC and DYNAMIC limits. See Section 4.3 – Technical Data for assistance.</p>
---	--

- Only qualified personnel shall operate the equipment. All operators shall be familiar with the equipment use and limitations. Ensure all safeguards are in place during operation.
- Never allow the jack to retract beyond the minimum closed position, as damage to the jack can occur.
- Mechanical stops are not typically provided with the screw jacks. Mechanical stops if provided are only auxiliary protective devices. Engaging a mechanical stop will cause damage to the jack that will result in premature failure. The user/integrator is responsible for installation of travel limits to ensure falling load hazards are mitigated and damage to the jack unit does not occur.
- For continuous or high-duty cycles inquire with your local sales representative or consult Joyce/Dayton regarding Bevel Ball Actuators.

- When fastening the jack to the load make sure the jack is in the retracted position. This positions the load accurately with respect to the jack screw centerline. Never pull the screw to one side to make connection with your structure. Fully extend the jack to make sure the load is aligned with the lifting screw.

7-4 Lifting Nut Inspection



WARNING: FALLING LOAD HAZARD! The lifting nut wear must be routinely monitored. The lifting nut must be replaced when worn excessively.

The sacrificial component within the screw jack is the bronze (Cu-Al alloy) lifting nut, also referred to as the worm wheel or worm gear. The lifting nut under normal use should not fail catastrophically, but will undergo significant wear on the external gear/nut teeth. Reduction in tooth thickness due to wear will result in eventual in-operability, (i.e., the jack will be unable to provide translation of the load).

Jacks have been necessarily designed in this manner to attempt to mitigate falling load risks. However, abnormal wear can occur and may manifest as focused wear on the nut internal (lead screw) thread in lieu of the external nut teeth. This mode of irregular wear may occur due to uneven loading, grease contamination, etc. This wear mode poses a falling load hazard and necessitates frequent inspection of the jack.

In the interest of safety and performance it is paramount that the wear of the jack be monitored and the jack be rebuilt/replaced once the wear is significant. Under normal wear conditions a general guideline for the lower limit of wear is 50% of the remaining external nut teeth. If, however, upon inspection it is determined that abnormal wear is present, (i.e., the internal thread is wearing more significantly than the external nut teeth) all jack components **MUST** be replaced immediately.

To further mitigate falling load risks it is the user's responsibility to supply safety provisions to assure safe operation in the presence of falling load hazards. These provisions are at the discretion of the user and may consist of machine safeguarding or assembly of hardware to arrest falling loads, (e.g., lead screw stop nuts). Contact Joyce/Dayton directly for more information regarding safety devices.

INSPECTION

For the most thorough and safe inspection, routine disassembly is required with subsequent review of all components. However, in many instances this is not practical or inspection itself may pose safety concerns. A less accurate method to monitor wear and mitigate falling load risks is to routinely measure lead screw backlash.

Measuring the backlash of the as shipped new unit and then conducting subsequent routine backlash measurements throughout the unit life will give an estimate to the wear rate based on comparison measurements. Acceptable backlash may vary per jack model and application, contact Joyce/Dayton for information or refer to the max allowable endplay given in the JAX software

7-5 TROUBLESHOOTING

Common jack problems are outlined below by symptom, cause, and correction. If faults cannot be repaired using the list below please contact Joyce/Dayton application engineering directly for assistance.

FAULT	POSSIBLE CAUSES	REPAIR
Lead screw does not translate with motor running.	<ul style="list-style-type: none"> a) Coupling failure or loss of engagement. b) Fractured worm input. c) Lift nut damage. 	<ul style="list-style-type: none"> a) Verify proper connection. b,c) Return unit to J/D for inspection/repair.
Unusual operating noise.	<ul style="list-style-type: none"> a) Clicking or grinding sound is possible bearing damage. b) Knocking sound is gearing related. c) Debris possibly within housing. d) Squealing is often due to misalignment, lack of lubrication, or exceeding duty cycle 	<ul style="list-style-type: none"> a) Check for adequate lubrication. b,c) Return to J/D for inspection/repair.
Excessive grease leakage	<ul style="list-style-type: none"> a) Possible failing seals. <p>Note: Some amount of oil/grease leakage with operation is expected.</p>	<ul style="list-style-type: none"> a) Inspect seals for damage and replace as necessary.
Excessive vibration during operation.	<ul style="list-style-type: none"> a) Incorrect alignment of coupling shafts. b) Unsecured/ loose jack mounting. 	<ul style="list-style-type: none"> a) Verify shaft alignment. b) Check all mounting fasteners.
Excessive jack temperature.	<ul style="list-style-type: none"> a) Exceeding duty cycle of jack unit. b) Possible failing bearings. c) Jack is overloaded. 	<ul style="list-style-type: none"> a) Limit the operational use. b) Inspect bearings for damage and replace as necessary. c) Verify proper loading conditions.

SECTION 8

EMERGENCY OPERATIONS



DANGER: Users/Integrators **MUST** evaluate and define emergency operations as part of risk analysis for the final system.

It is imperative that provisions for emergency operation be addressed by the user/integrator. Jacks can be self-locking holding load to some extent, but this is not to be relied upon since the locking ability varies among jack models and a damaged jack may lose this ability altogether. The inclusion of an emergency hand crank into the system may help mitigate some risks, thereby providing a means to relieve load. However, other means should be provided as well.

SECTION 9

DECOMMISSIONING & RECOMMISSIONING

- When jacks are removed from service for long periods they should be stored indoors in areas that are free from contaminants, (e.g., dust and moisture). Preventative measures should be taken to prevent corrosion or damage.
- When recommissioning users must read and understand the contents of this manual.
- If the jack has been stored for a significant period of time it is always recommended that the lubricant be purged from the unit and replaced with new grease.

SECTION 10

DISPOSAL

Jacks are composed mainly of recyclable metals. However, some lubricants and plastics may also be present. Materials shall be separated and disposed of appropriately.

SECTION 11

REPAIR & REPLACEMENT

11-1 REPAIR PARTS



CAUTION: SAFETY HAZARD! Use only Joyce Dayton approved replacement parts. Use of non-approved parts will void warranty and pose safety hazards.

Only Joyce Dayton approved repair parts shall be used on the jack screws. Use of any other parts will void warranty and pose possible risks to safety. Obtain repair parts by contacting your local sales representative or by contacting:

Joyce Dayton Customer Service

Phone: (800) 523-5204 or (937) 294-6261

Fax: (937) 297-7371

Email: sales@joycedayton.com

Please have the serial number from the jack nameplate available. Recommended repair parts for rebuilding or spares are listed by model below:

Quantity	Part Description	250 LB. – 1-ton	2-ton – 75-ton	100-ton – 250-ton
2	Thrust Bearing	✓	✓	✓
1	Worm Gear	✓	✓	✓
2	Worm Shaft Bearing	✓	✓	✓
2	Worm shaft seal	-----	✓	✓
2	Retaining Clip (worm shaft)	✓	-----	-----
	Shims - assortment	-----	✓	✓
	Base Shim	-----	-----	✓
1	Worm	✓	✓	✓
1	Lifting Screw	✓	✓	✓
1 or 2	Boot(s)	✓	✓	✓
1	Traveling Nut (KFTN style)	✓	✓	✓
1	Key (keyed for non-rotation)	✓	✓	✓
2	Internal Seal (translating and keyed SS Jacks only)	-----	✓	-----
1	Seal (SS KFTN Jacks only)	-----	✓	-----

11-2 DISASSEMBLY

TRANSLATING AND KEYED MODELS

* Handle all machined parts with care and maintain an “order of disassembly” to aid re-assembly.

1. If the jack is equipped with a boot, remove boot clamps, and collapse or remove the boot.
2. Remove the sleeve cap by loosening four set screws in the sleeve cap and rotating the sleeve cap counter clockwise.
3. Unthread and remove the protection tube with a pipe wrench or strap wrench.
4. Remove any travel stops that may be on the lifting screw and unthread the lifting screw from the body of the jack. Rotate the input worm shaft on keyed jacks to remove the lifting screw.
5. Remove thrust bearings and worm gear from the internal cavity. Bearing races are pressed onto the worm gear so these parts may come out fastened together.

6. For 2-ton and larger jacks, remove screws from the worm bearing caps and remove the bearing caps, shims, and seals. Use caution to avoid seal damage from the keyway on the shaft. Carefully remove shims. Keep track of the number and color of shims as an aid to reassembly. Skip to item 8.
7. For smaller jacks, remove the retaining clips (snap rings). There will be no shims.
8. Remove the worm shaft bearings. These are press fit and may require a plastic mallet to be dislodged.

KEYED FOR TRAVELING NUT MODELS (KFTN)

* Handle all machined parts with care and maintain an “order of disassembly” to aid re-assembly.

1. If the jack is equipped with a boot or with dual boots, remove boot clamp(s), and collapse or remove the boot(s).
2. The traveling nut may be unthreaded from the lifting screw. Remove screw stops if necessary.
3. Remove the sleeve cap by loosening four set screws in the sleeve cap and rotating the sleeve cap counter clockwise.
4. Remove the screw assembly from the cavity of the jack sleeve. The assembly consists of the machine screw, the upper thrust bearing, the key, and the worm gear.
5. The upper and lower thrust bearings must be removed from the nut before they can be replaced. Since they are pressed onto the gear nut, a tool may be needed to pull them. On inverted KFTN jacks it is necessary to remove the lifting screw before this step can be accomplished.
6. For 2-ton and larger jacks, remove screws from the worm bearing caps and remove the bearing caps, shims, and seals. Use caution to avoid seal damage from the keyway on the shaft. Carefully remove shims. Keep track of the number and color of shims as an aid to reassembly. Skip to item 8.
7. For smaller jacks, remove the retaining clips (snap rings). There will be no shims.
8. Remove the worm shaft bearings. These are press fit and may require a plastic mallet to be dislodged.

Disassembly of ComDRIVE® Jacks

1. Remove the (4) bolts and washers from the adapter/reducer f-flange . The reducer and motor can now be removed from the jack. The motor included with the ComDRIVE® is not user serviceable, however, it can be replaced. Replacement parts for the gear reducer can be obtained from Joyce/Dayton by contacting sales@joycedayton.com.
2. Use the appropriate disassembly procedure for the ComDRIVE® jack– if the lifting nut is outside the jack on the screw, it is a Keyed for Traveling Nut (KFTN) jack, (also called a “rotating screw” jack), otherwise the jack is a translating model or a keyed model. Handle machined parts with care, and maintain an “order of disassembly” to aid in re-assembly. Remove all couplings, screw support bearings, etc. before beginning disassembly.

11-3 Inspection

Inspection of screw jack components is a necessary step in the maintenance process allowing customers to identify any components that need to be repaired. Thoroughly clean all jack components before inspecting them for damage and wear.

1. Sleeve and sleeve cap – Visually inspect for signs of damage and stress fractures. Use 10X magnification around mounting holes.
2. Worm shaft – Visually inspect for signs of brinelling, abrasive wear, or spalling. Roll the worm on a flat surface to check for straightness. Verify the keyways and keys are not damaged.
3. Thrust bearings and Worm Shaft bearings – Visually inspect the overall condition of bearing and check for smooth, quiet operation.
4. Bearing caps – Visually inspect for indications of stress and damage.
5. Aluminum bronze gear nut – Visually inspect for signs of excessive wear.
6. Lifting screw – Visually inspect for signs of excessive wear and thinning threads. Roll on a flat surface to check for straightness.
7. Traveling Nut – On KFTN jacks only – Visually inspect for signs of excessive wear and thinning threads.

8. Boots – Visually inspect for wear and cracks.
9. Seals – All seals must be replaced.

11-4 ASSEMBLY

TRANSLATING AND KEYED MODELS

1. Prepare parts for reassembly
 - a. Cover sharp edges of the worm shaft keyway with masking tape for protection.
 - b. Ensure that all bearings are packed with grease
 - c. Coat seals with light oil
2. Be sure that thrust bearings are seated properly on the worm gear and in the housing.
3. Insert the worm gear, bearings and worm input shaft into the cavity. Some jacks require that the worm input shaft be installed prior to installing the worm gear and bearings because of space limitations.
4. Thread sleeve cap onto housing and hand tighten.
5. Install worm shaft bearings over the worm shaft ends on either end of the worm shaft and press the bearings into the jack housing.
6. Carefully slide seals over worm input shafts being careful not to damage them (2-ton and larger jacks). Install retaining clips (snap rings) on 250 lb through 1-ton jacks.
7. Replace shims on both input shafts using the same number and color as were disassembled from 2-ton through 75-ton jacks. This number may vary and this portion of the assembly is an iterative process.
8. Assemble worm shaft bearing caps on 2-ton and larger jacks. Systematically tighten bearing cap screws to ensure even loading on each fastener.
9. Check the input shaft for excessive or deficient axial or lateral movement – an iterative process.
 - a. If the input shaft feels loose and the input shaft rotates too easily, remove the bearing cap and then remove a shim.
 - b. If the input shaft is too tight and it is difficult to rotate, remove the bearing cap and add a shim to one or both sides.
 - c. Recheck the feel of the jack after striking the input shaft with a solid blow from a soft rubber mallet on each end (axial direction). Make any adjustments needed per step 10a or 10b.
 - d. The correct set-up has a solid feel without play (axial or lateral) and the input shaft rotates with a smooth but snug feel.
10. The thrust bearing pre-load now needs to be set.
 - a. Rotate the input shaft while tightening the sleeve cap
 - b. Check the rotation of the input shaft as the sleeve cap is tightened.
 - c. Strike the top of the sleeve cap with a dead blow mallet to help seat the bearings.
 - d. When the sleeve cap will tighten no further by hand systematically tighten the set screws on the sleeve cap.
11. Lubricate the bearings and cavity per Section 7 and apply grease to the length of the lifting screw.
12. Thread the protection tube onto the jack assembly.
13. Assemble any boots that may be included with the jack.

KEYED FOR TRAVELING NUT MODELS (KFTN)

*Assembly is the reverse of disassembly.

1. Prepare parts for reassembly
 - a. Cover sharp edges of the worm shaft keyway with masking tape for protection.
 - b. Ensure that all bearings are packed with grease
 - c. Coat seals with light oil
2. Be sure that thrust bearings are seated properly on the worm gear and in the housing.

3. Assemble the worm gear nut and key to the lifting screw and secure it with the retaining clip.
4. Install the worm input shaft in housing and install worm shaft bearings in place at either end of the worm shaft. Press bearings into housing.
5. Carefully slide seals over worm input shafts being careful not to damage them (2-ton and larger jacks). Install retaining clips (snap rings) on 250-lb. through 1-ton jacks.
6. Insert the worm gear nut and screw assembly into the cavity. Some jacks require that the worm input shaft be installed prior to installing the worm gear and bearings because of space limitations.
7. Thread sleeve cap onto housing and hand tighten.
8. Replace shims on both input shafts using the same number and color as were disassembled from 2-ton through 75-ton jacks. This number may vary and this portion of the assembly is an iterative process.
9. Assemble worm shaft bearing caps on 2-ton and larger jacks. Systematically tighten bearing cap screws to ensure even loading on each fastener.
10. Check the input shaft for excessive or deficient axial or lateral movement (2-ton and larger jacks)
 - a. If the input shaft feels loose and the input shaft rotates too easily, remove the bearing cap and then remove a shim.
 - b. If the input shaft is too tight and it is difficult to rotate, remove the bearing cap and add a shim to one or both sides.
 - c. Recheck the feel of the jack after striking the input shaft with a solid blow from a soft mallet on each end (axial direction). Make any adjustments needed per step 10a or 10b.
 - d. The correct set-up has a solid feel without play (axial or lateral) and the input shaft rotates with a smooth but snug feel.
11. The thrust bearing pre-load now needs to be set.
 - a. Rotate the input shaft while tightening the sleeve cap
 - b. Check the rotation of the input shaft as the sleeve cap is tightened.
 - c. Strike the top of the sleeve cap with a dead blow mallet to help seat the bearings.
 - d. When the sleeve cap will tighten no further by hand systematically tighten the set screws on the sleeve cap.
12. Thread the traveling nut onto the lifting screw.
13. Lubricate the bearings and cavity per Section 7 and apply grease to the length of the lifting screw.
14. Assemble any boots that may be included with the jac

MACHINE SCREW JACK COMPONENT LIST

Note: When ordering supply the jack serial number along with the item number. Due to the multitude of components used by Joyce Dayton engineering will determine the associated part number.

Item	Part Description	Quantity
1	Sleeve	1
2	Thrust Bearing	2
3	Worm Gear	1
4	Sleeve Cap	1
5	Sleeve Cap Set Screws	4
6	Worm Shaft	1
7	Worm Shaft Bearing	2
8	Retaining Ring	2
9	Lifting Screw	1
10	Protection Tube	1
11	Bushing	1
12	Key	1
13	Key (KFTN)	1
14	Retaining Ring	1
15	Traveling Nut	1
16	Grease Fitting	1 to 3
17	Bellows Boot (optional - not shown on 100/150 Ton Model)	1
18	Bellows Boot Clamp (optional - not shown)	2
19	Worm Shaft Seal	2
20	Shims	2 to 6
21	Bearing Cap	2
22	Bearing Cap Lockwasher	6 to 16
23	Bearing Cap Screw	6 to 16
24	Key Screw	0 to 2
25	Base Plate	1
26	Protection Tube Adaptor/Bushing	1
27	O-Ring	1
28	V-Ring Seal (100/150 Ton Model Only)	2
29	Shims	1 to 3
30	Base Plate Screws	20
31	Dowel Pins	4
32	Set Screws	2
33	Keyed Cap (Not Sleeve Cap)	1
34	Keyed Cap Screws	6
35	Vent	1
36	Pipe Plug	1
37	Name Plate (not shown)	1
38	Name Plate Drive Screws (not shown)	2
39	Internal Seal (Stainless Steel Translating and Keyed)	2
40	Protection Tube Adaptor Bushing (SS Jacks)	1
41	Seal (SS KFTN Style Jacks)	1

100/150 Ton
Model Only

ADDITIONAL COMDRIVE COMPONENTS - MODELS 2 THRU 30 TON

Note: When ordering supply the jack serial number along with the item number.
 Due to the multitude of components used by Joyce Dayton engineering will determine the associated part number.

Item	Part Description	Quantity
1	Gear Reducer	1
2	Hex Head Screw	4
3	Lock Washer	4
4	Electric Motor	1
5	Hex Head Screw	4
6	Lock Washer	4
7	Woodruff Key	1
8	Hex Head Screw	6 to 8
9	Lock Washer	6 to 8
10	Reducer Mounting Adaptor	1
11	ComDrive Seal	1
12	Screw Stop	1 to 2
13	Set Screw	2 to 4

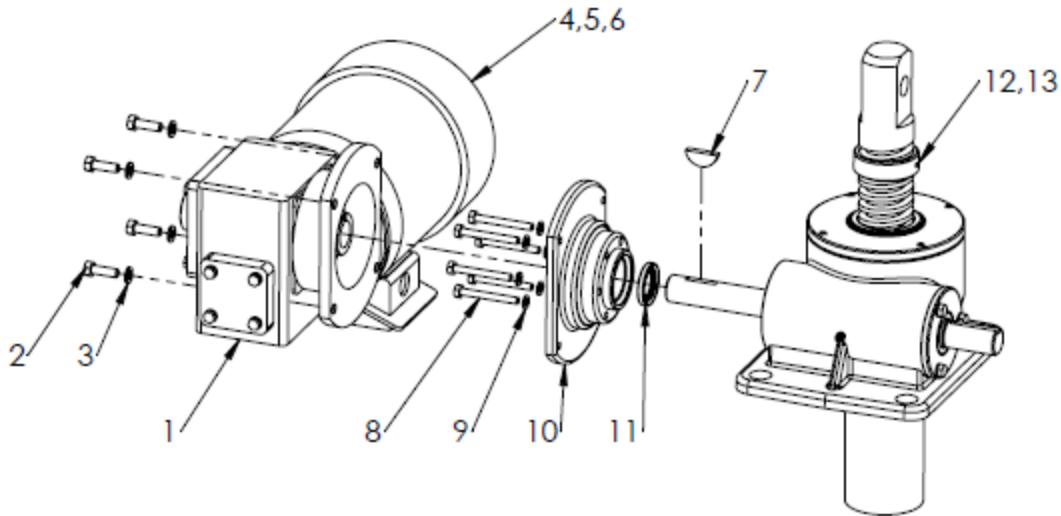

Upright Model Depicted

EXPLODED COMPONENTS VIEW - MODELS 250 LBS THRU 1 TON AND 10kN

(WJ250/500/1000, WJ51, WJ201, MWJ51, MWJ201)

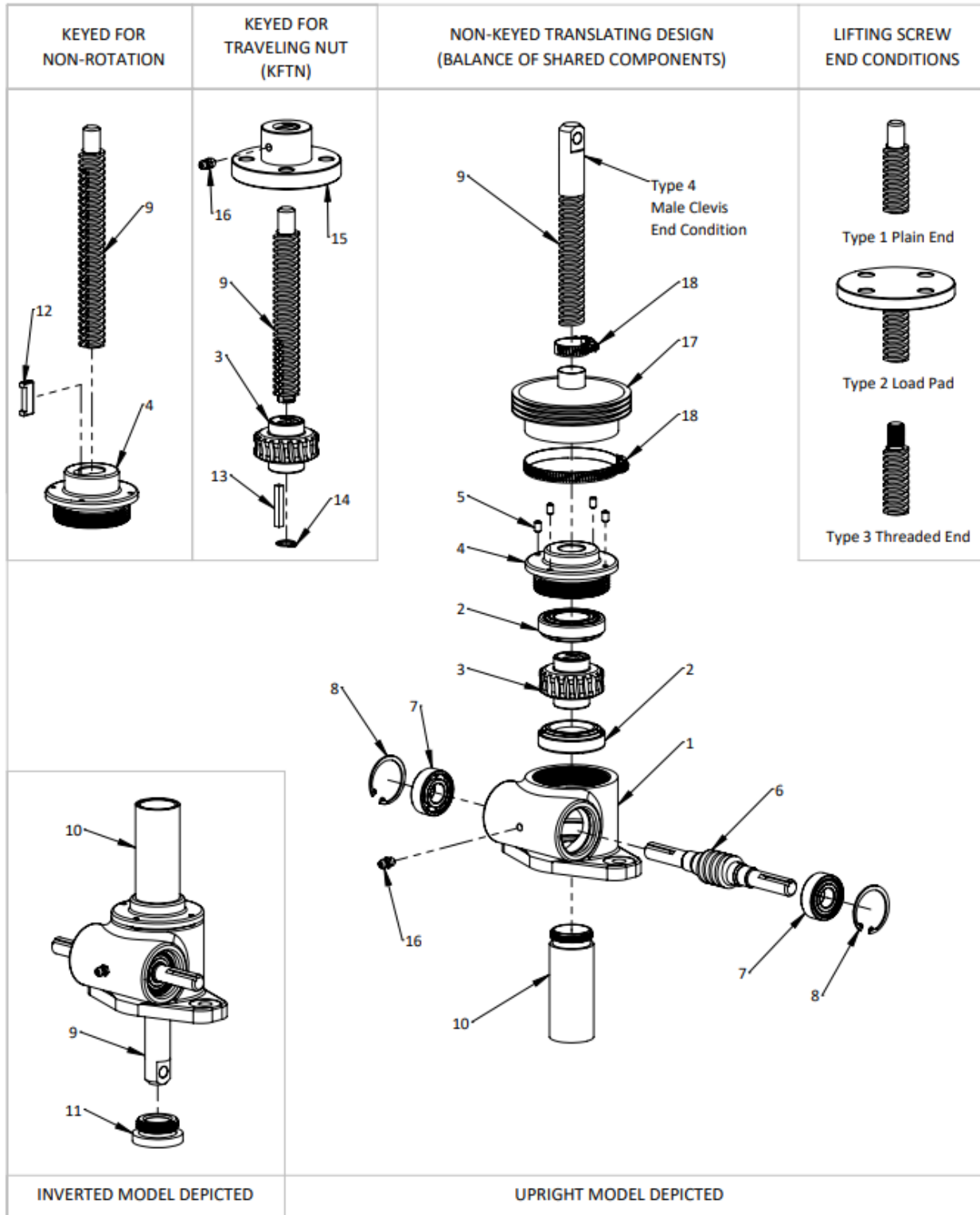

EXPLODED COMPONENTS VIEW - MODELS 2 THRU 75 TON - 25kN THRU 100kN

(WJ, WJT, RWJT, DWJ, DWJ, DRWJ, MWJ)

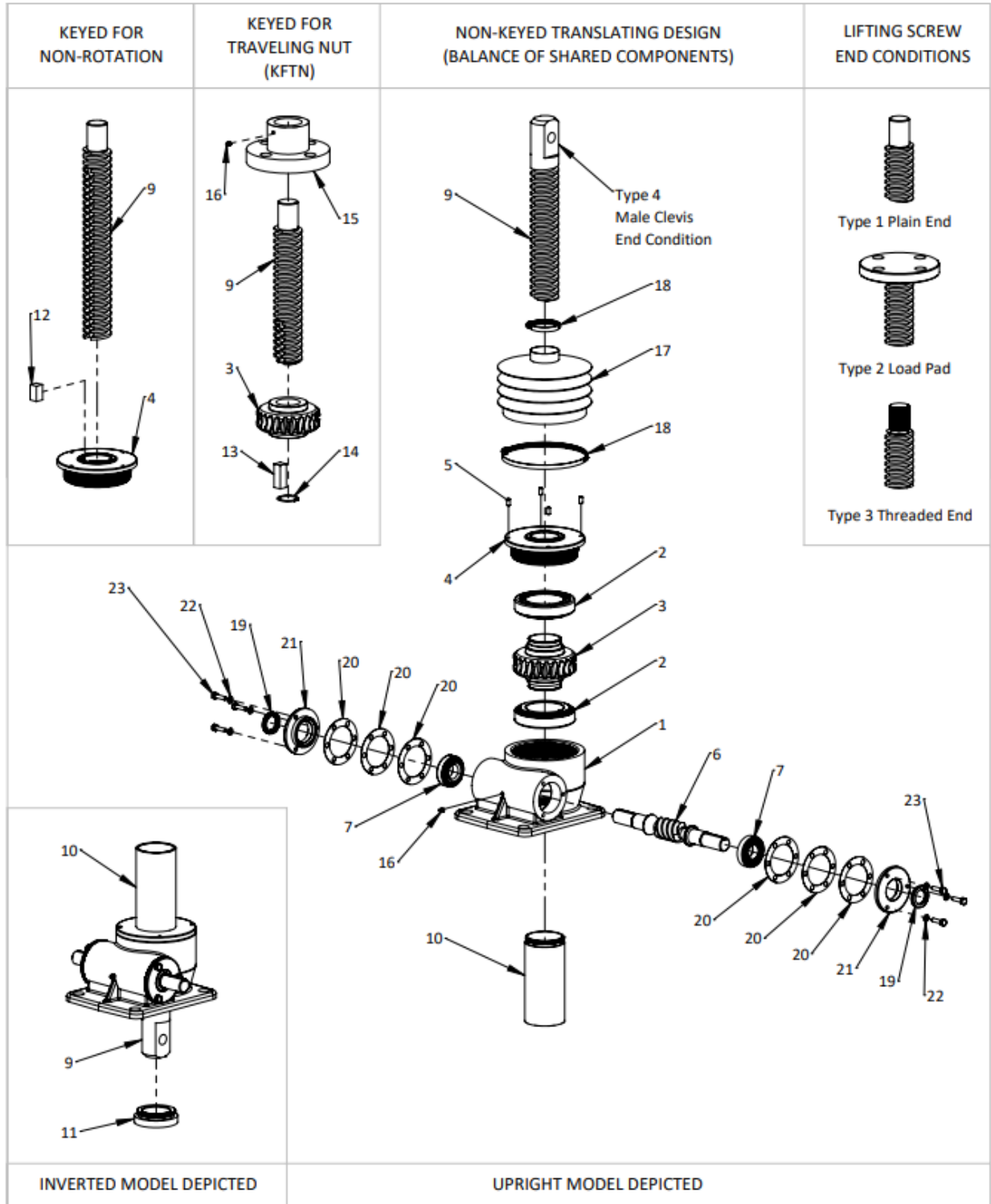

**EXPLODED COMPONENTS VIEW
STAINLESS STEEL MODELS 2 THRU 25 TON
(SWJ, DSWJ, RSWJ, DRSWJ)**

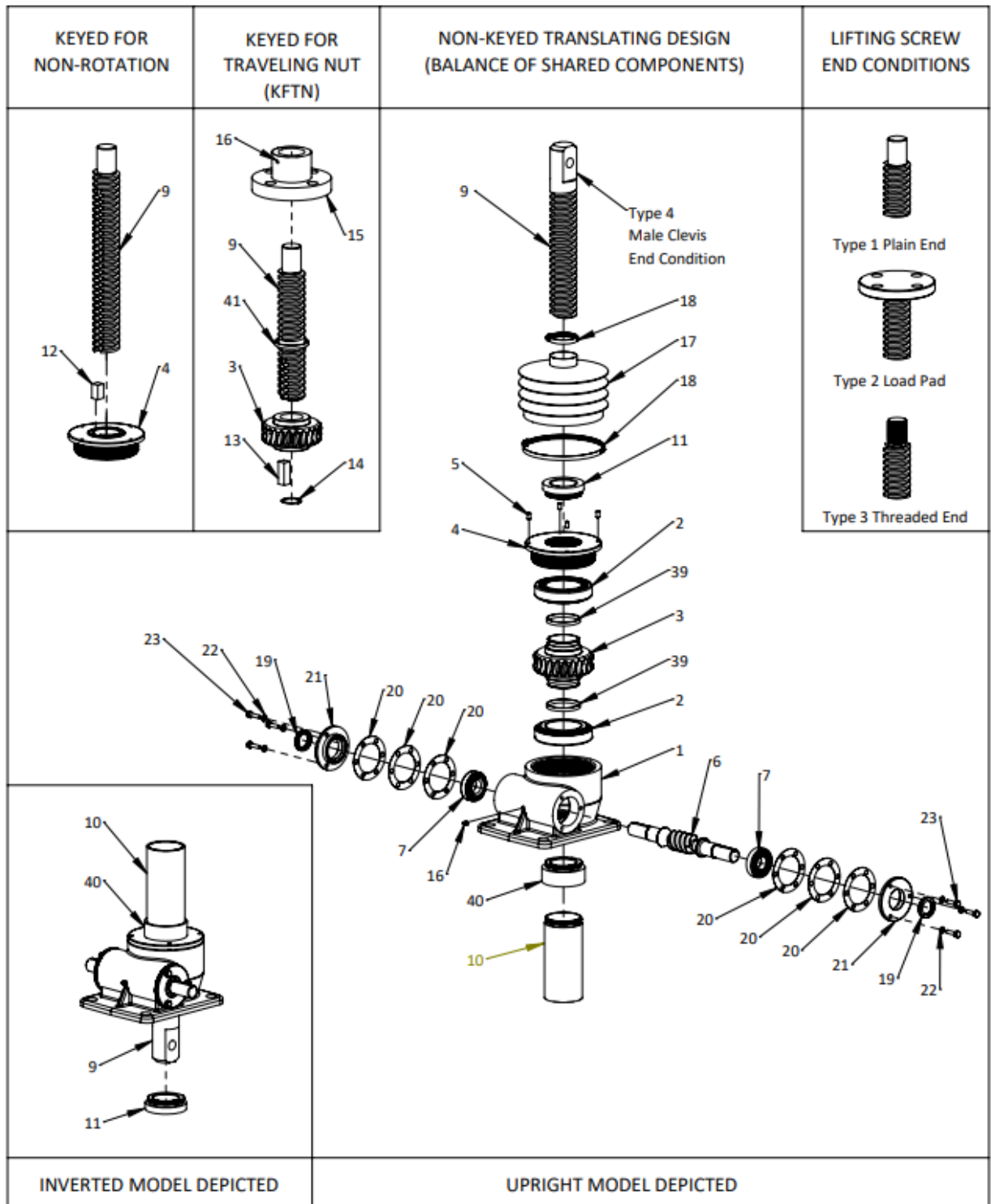

EXPLODED COMPONENTS VIEW - MODELS 100 AND 150 TON
(WJ12100/WJ36100, WJ12150/WJ36150)

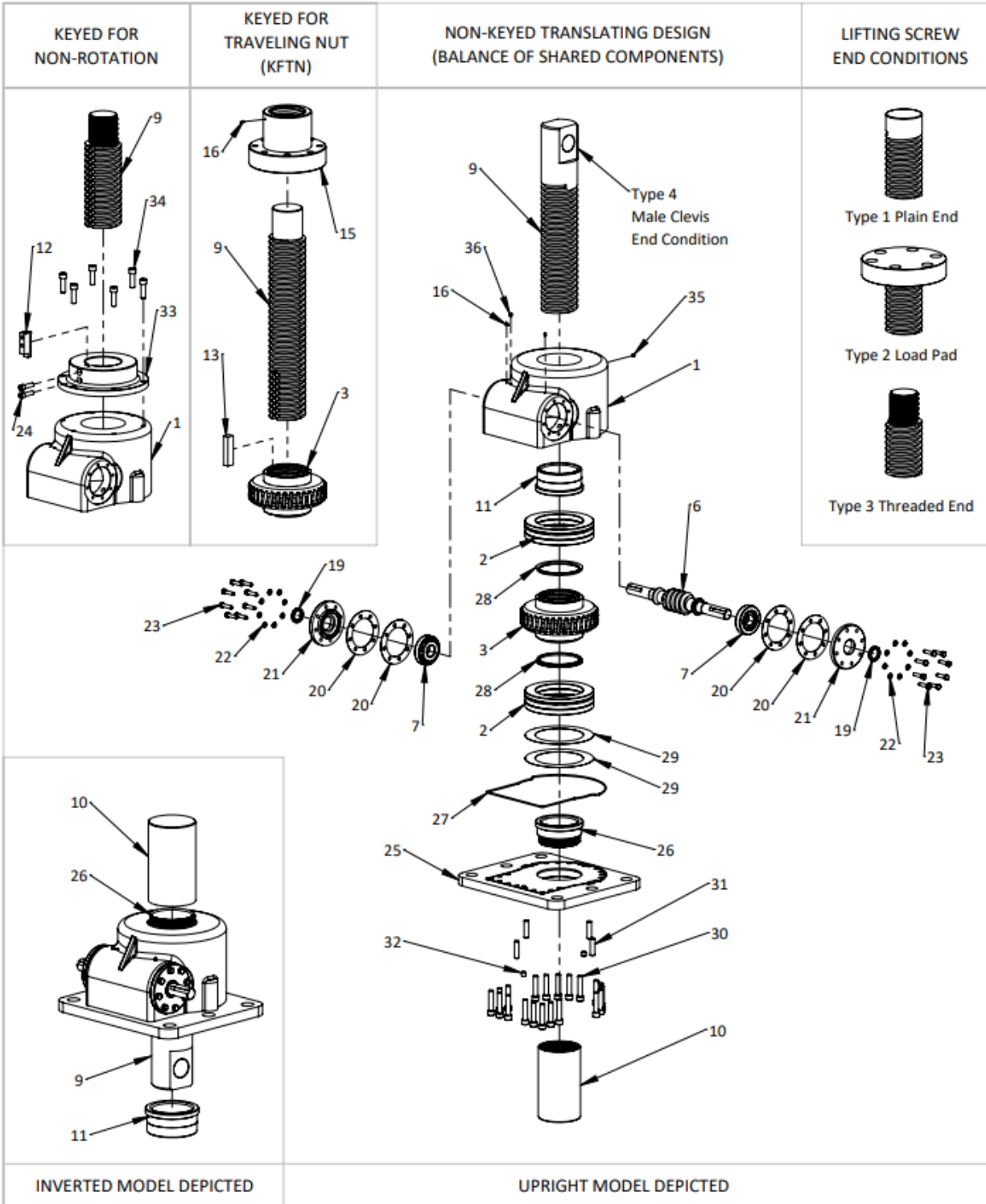

Approximate Jack Weights Standard and Stainless			
Model	Static Capacity*	Basic Weight (lb)	Add to Basic Weight (lb) for each 1" of Screw Length
WJ250	250 lb	1.2	0.1
WJ500	500 lb	1.3	0.1
WJ1000	1000 lb	1.3	0.1
WJ51, 201	1 TON	6	0.3
(R)WJT62, 122, 242, 252	2 TON	15	0.3
(D)(R)(S)WJ62, 122, 242	2 TON	15	0.3
(D)WJ63, 123, 243, 253	3 TON	17	0.4
WJT65, 125, 245, 255	5 TON	32	0.7
(D)(DS)(S)WJ65, 125, 245	5 TON	32	0.7
(S)WJ810, 2410, 2510	10 TON	43	1.3
(D)(DS)WJ810, 2410	10 TON	43	1.3
(D)(DS)(S)WJ815, 2415	15 TON	59	1.4
WJ2515	15 TON	59	1.4
(D)(S)WJ820, 2420	20 TON	77	1.9
(D)(DS)(S)WJ1125, 3225	25 TON	164	3.0
(D)WJ1130,3230	30 TON	164	3.1
WJ1135,3235	35 TON	240	3.4
(R)WJT1150,3250	50 TON	387	6.1
WJ1175,3275	75 TON	610	6.5
WJ12100,36100	100 TON	1010	10.0
WJ12150,36150	150 TON	1350	12.2
WJ50250	250 TON	3415	21.0
*Jack static capacity is limited by lead screw length. Reference JAX software or catalog for proper capacity.			
*These weights are estimated and do not account for added mounting fixtures, (e.g., trunnion assemblies), reducers or motors.			

Approximate Jack Weights Metric			
Model	Static Capacity*	Basic Weight (kg)	Add to Basic Weight (kg) for each 25mm of Screw Length
MWJ51, 201	10 kN	2.7	0.14
MWJ62.5, 122.5, 242.5	25 kN	6.8	0.18
MWJ65, 125, 245	50 kN	14.5	0.32
MWJ810, 2410	100 kN	19.5	0.59
*Jack static capacity is limited by lead screw length. Reference JAX software or catalog for proper capacity.			
*These weights are estimated and do not account for added mounting fixtures, (e.g., trunnion assemblies), reducers or motors.			

